

Fig No: DA56 / SR 56

1/2" ~ 3" (DN 15 ~ DN 80)

DA: Double Acting SR: Spring Return



Valve Specification :

Design Specification According to EN-12516-1

Material : Stainless Steel, Carbon Steel or Special Alloy upon request

Blow-out-proof stem design & Anti-static design

Stem packing to comply with **TA-Luft** requirements

Actuator Mounting shall be in accordance with ISO 5211

Flange Dimension according to 1/2" ~ 2"DIN 2543 PN 40 ,
2-1/2" ~ 4"DIN 2543 PN 16

Working Pressure according to EN-12516-1 PN 16 / 40 Flanged type

Temperature Range : -4 to 356 °F (-20 to 180 °C)

Pressure Test According to API 598

Shell test by water : working pressure x 1.5 time

Closure seat by Air : 6.9 bar

DETAIL "X"

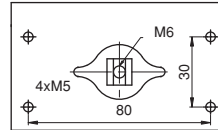

MATERIALS LIST

NO.	PART NAME	MATERIAL	Q'TY
1	BODY	ASTM A351 Gr.CF8M	1
2	BALL	ASTM A351 Gr.CF8M	1
3	END CAP	ASTM A351 Gr.CF8M	1
4	BODY SEAL	PTFE.	1
5	STEM	SS316	1
7	STEM PACKING	PTFE.	1SET
9	SEAT	PTFE. , RTFE.	2
10	THRUST WASHER	PTFE.	1
17	STEM NUT	SS304	1
18	TAB WASHER	SS304	1
21	BELLEVILLE WASHER	SS301	1SET
23	STEM BUSH	PTFE+15%GF	1
24	O-RING	VITON	1
39	PNEUMATIC ACTUATOR	ALUMINUM	1

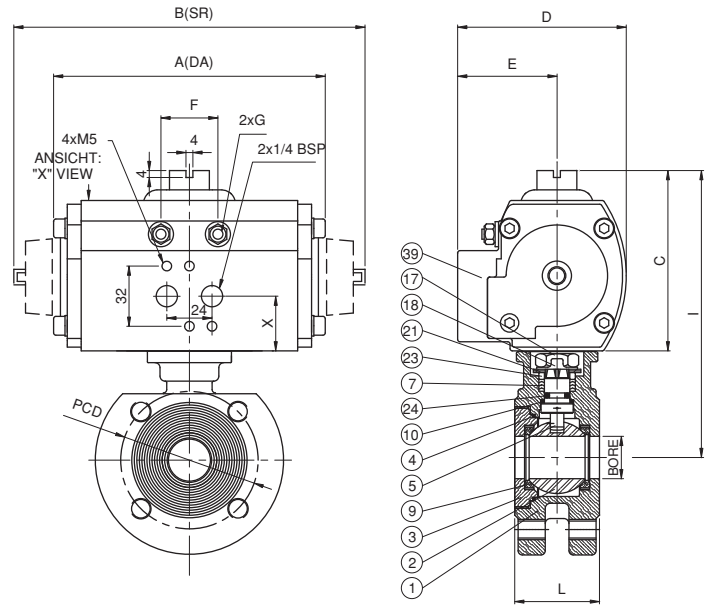

DIMENSIONS

Unit:mm

SIZE	1/2"		3/4"		1"		1-1/4"		1-1/2"		2"		2-1/2"		3"		4"	
Air Supply	80 PSI		80 PSI		80 PSI		80 PSI		80 PSI		80 PSI		80 PSI		80 PSI		80 PSI	
ACTUATOR	DA	SR	DA	SR	DA	SR	DA	SR	DA	SR	DA	SR	DA	SR	DA	SR	DA	SR
	C-125	C-250 SR2	C-125	C-250 SR2	C-250	C-250 SR4	C-250	C-450 SR3	C-450	C-450 SR4	C-450	C-1000 SR3	C-1000	C-2250 SR3	C-2250	C-2250 SR4	C-2250	C-2250 SR4
BORE	15.0		20.0		25.0		32.0		38.0		50.0		63.0		77.0		96.0	
PCD	65.0		75.0		85.0		100.0		110.0		125.0		145.0		160.0		180.0	
A	120.0	**	120.0	**	144.3	**	144.3	**	149.2	**	149.2	**	183.0	**	259.6	**	259.6	**
B	**	194.6	**	194.6	**	194.6	**	205.6	**	205.6	**	250.0	**	355.0	**	355.0	**	355.0
C	84.0	99.0	84.0	99.0	99.0	99.0	99.0	118.0	118.0	118.0	118.0	141.0	141.0	161.0	161.0	161.0	161.0	161.0
D	82.2	81.4	82.2	81.4	81.4	81.4	81.4	95.0	95.0	95.0	95.0	119.0	119.0	140.5	140.5	140.5	140.5	140.5
E	33.7	47.8	33.7	47.8	47.8	47.8	47.8	51.5	51.5	51.5	51.5	64.5	64.5	75.5	75.5	75.5	75.5	75.5
F	24.0	32.5	24.0	32.5	32.5	32.5	32.5	32.5	32.5	32.5	32.5	46.2	46.2	54.0	54.0	54.0	54.0	54.0
G	MxP0.8	M5xP0.8	MxP0.8	M5xP0.8	M5xP0.8	M5xP0.8	M5xP0.8	M6xP1.0	M6xP1.0	M6xP1.0	M6xP1.0	M8xP1.25	M8xP1.25	M10xP1.5	M10xP1.5	M10xP1.5	M10xP1.5	M10xP1.5
H	23.5	29.7	23.5	29.7	29.7	29.7	29.7	30.2	30.2	30.2	30.2	33.5	33.5	39.0	39.0	39.0	39.0	39.0
I	139.0	153.0	141.5	156.5	161.5	161.5	174.0	193.0	207.0	207.0	212.6	235.6	253.8	273.8	290.3	290.3	305.3	305.3
L	40.8		44.0		50.0		60.0		65.0		80.0		110.0		120.0		150.0	

FLANGE DIMENSION ACCORDING TO 1/2" ~2" DIN 2543 PN40
2-1/2" ~4" DIN 2543 PN16