

## Fig No: Y-15

1/2" ~ 2-1/2" ( DN 15 ~ DN 300 )

DA:Double Acting SR:Spring Return



### Actuator :

Type : Single Cylinder

Cylinder Material : SUS304

Air Supply : 3-6 kg/cm<sup>2</sup>

Ambient Temperature : -20°C ~ +60°C

### Valve Action :

Air to open or air to Close by using direct or reverse actuator.

### Accessory :

Solenoid Vlve, Limit Switch, Air Set or Others. Rate Cv Valve

## MATERIALS LIST

NO.	PART NAME	MATERIAL
1	BODY	CF8M
2	PLUNGER	AL
5	STEM	SS304
5-1	SPRING	STEEL
9	CAP	CF8M
11	BODY SEAL	PTFE.
12	SEAT	SS316
14	PACKING	TEFLON
14-1	PACKING	TEFLON
14-2	PACKING	TEFLON
22	NUT	SS316
23	SPRING WASHER	SS301
30	STOP WASHER	SS316
31	O-RING	NBR
35	BOLT	SS304
37	HEX.NUT	SS304
66	MOUNTING BRACKET	SS316
67	ACTUATORS	SS316

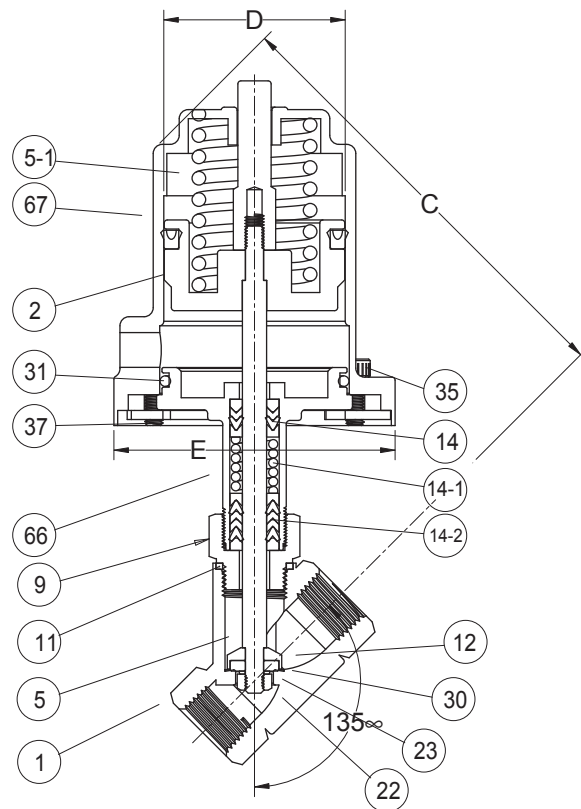

## DIMENSIONS

Unit:mm

SIZE	1/2"	3/4"	1"	1-1/4"	1-1/2"	2"	2-1/2"
C	149.0	156.0	163.0	201.0	200.0	210.0	255.0
E	93.0	93.0	93.0	117.0	117.0	117.0	117.0
D	60.0	60.0	60.0	85.0	85.0	85.0	85.0
MAX.PRESSURE (KG/CM <sup>2</sup> )	0~16	0~16	0~16	0~16	0~16	0~16	0~16