

Fig No:EL-83HP

1/2" ~ 2" (DN 15 ~ DN 50)



Valve Specification :

Design specification according to EN 12516-3

Material:Stainless steel, carbon steel or special alloy upon request

Blow-out-proof stem design & Anti-static design

Actuator Mounting shall be in accordance with ISO 5211

Working Pressure (CWP) : 1000 Psi

Temperature Range : -4 to 356 °F (-20 to 180 °C)

Pressure Test According to API 598

Shell test by water : 1200 Psi

Closure seat by Air : 80 ~ 100 Psi

MATERIALS LIST

NO	PART	MATERIAL	Q,TY
1	BODY	ASTM A351 GR.CF8M	1
2	BALL	ASTM A351 GR.CF8M	1
3	INSERT	ASTM A351 GR.CF8M	1
4	BODY SEAL	PTFE	1
5	STEM	SS316	1
6	FOLLOWER	SS304	1
7	STEM PACKING	PTFE	1SET
9	SEAT	PTFE	2
10	THRUST WASHER	PTFE	1
17	STEM NUT	SS304	1
20	BOLT	SS304	4
21	BELLEVILLE WASHER	SS304	2
24	O-RING	VTON	2
39	ELECTRIC ACTUATOR	NYLON	1

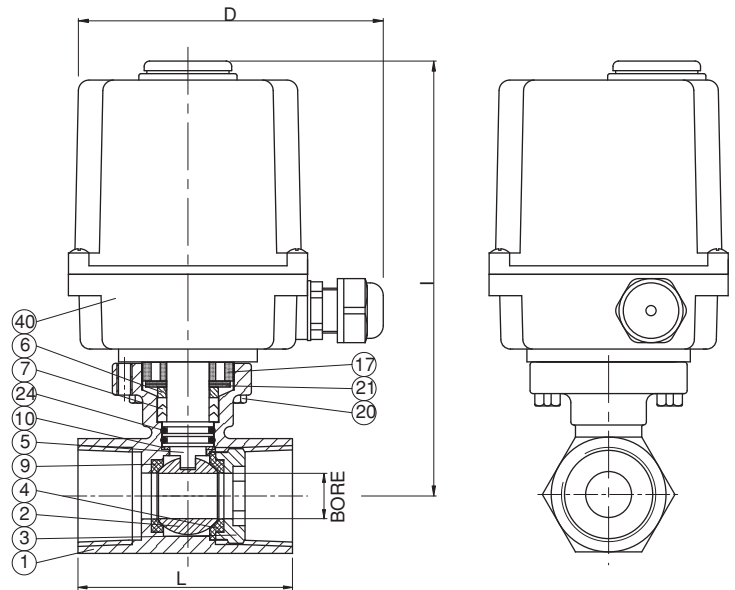

DIMENSIONS

Unit:mm

SIZE	1/2"				3/4"				1"				1-1/4"				1-1/2"				2"				
	UMS		UM-1		UMS		UM-1		UMS		UM-1		UMS		UM-1		UMS		UM-1		UM-1				
VOLTAGE	110 VAC	220 VAC	24 VAC	24 DVC	110 VAC	220 VAC	24 VAC	24 DVC	110 VAC	220 VAC	24 VAC	24 DVC	110 VAC	220 VAC	24 VAC	24 DVC	110 VAC	220 VAC	24 VAC	24 DVC	110 VAC	220 VAC	24 VAC	24 DVC	
BORE	9.2				12.5				16.0				20.0				25.0				32.0				
D	136.2	136.2	136.2	148.0	136.2	136.2	136.2	148.0	136.2	136.2	136.2	148.0	136.2	136.2	136.2	148.0	136.2	136.2	136.2	148.0	148.0	148.0	148.0	148.0	148.0
I	139.8	139.8	139.8	186.3	142.3	142.3	142.3	188.8	141.4	141.4	141.4	187.9	149.0	149.0	149.0	195.5	155.2	155.2	155.2	201.7	207.3	207.3	207.3	207.3	207.3
L	56.5				59.0				71.0				79.2				85.9				100.0				