

## Fig No:EL-155A

1/2" ~ 2-1/2" ( DN 15 ~ DN 65 )



### Valve Specification :

#### Design Specification According to ANSI B16.34

Material : Stainless Steel, Carbon Steel or Special Alloy upon request  
Blow-out-proof stem design & Anti-static design

Stem packing to comply with **TA-Luft** requirements

Actuator Mounting Shall be in accordance with ISO 5211

In-Line Maintenance

End Connection: Threaded / Socket Weld / Butt Weld

Working Pressure : 1/2" ~ 1" 2000 Psi / 1-1/4" ~ 2" 1500 Psi

Temperature Range : -4 to 356 °F ( -20 to 180 °C )

Pressure Test According to API 598 :

Shell test by water : 1/2" ~ 1" 3000 Psi / 1-1/4" ~ 2" 2250 Psi

Closure seat by Air : 80 ~ 100 Psi

### MATERIALS LIST

NO	PART NAME	MATERIAL	Q'TY
1	BODY	ASTM A351 GR. CF8M	1
2	END CAP	ASTM A351 GR. CF8M	2
3	BALL	ASTM A351 GR. CF8M	1
4	BODY SEAL	PTFE.	2
5	STEM	SS316	1
6	FOLLOWER	SS304	1
7	STEM PACKING	NRG	1 SET
9	SEAT	RTFE.	2
10	THRUST WASHER	NRG	1
17	STEM NUT	SS304	1
18	TAB WASHER	SS304	1
19	BOLT NUT	SS304	4~12
20-1	BOLT NUT	SS304	4~12
20-2	MOUNTING BOLT	SS304	8
21	BEVELILLE WASHER	SS301	1 SET
29	BOLT WASHER	SS304	4~12
37	MOUNTING BRACKET	SS304	1
38	ADAPTER	SS304	1
40	ELECTRIC ACTUATOR	NYLON	1

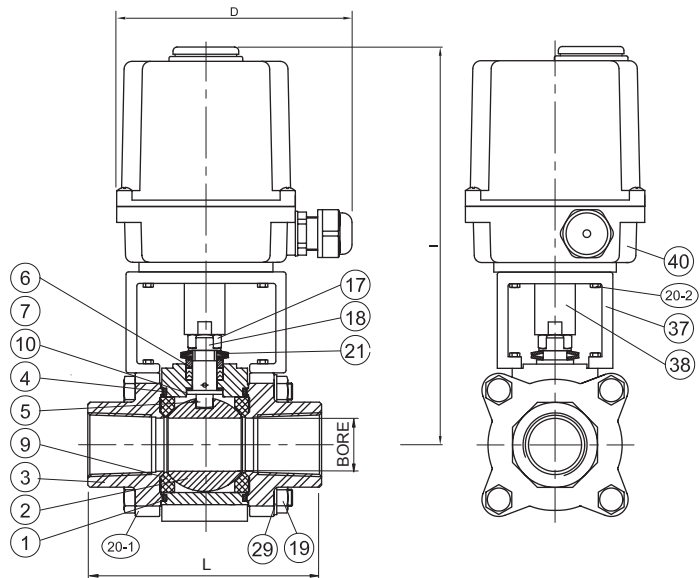

### DIMENSIONS

Unit:mm

SIZE	1/2"				3/4"				1"				1-1/4"				1-1/2"				2"				2-1/2"			
	UMS		UM-1		UMS		UM-1		UMS		UM-1		UM-1		UM-1		UM-1		UM-1		UM-1		UM-2					
<b>VOLTAGE</b>	110 VAC	220 VAC	24 VAC	24 DVC	110 VAC	220 VAC	24 VAC	24 DVC	110 VAC	220 VAC	24 VAC	24 DVC	110 VAC	220 VAC	24 VAC	24 DVC	110 VAC	220 VAC	24 VAC	24 DVC	110 VAC	220 VAC	24 VAC	24 DVC	110 VAC	220 VAC	24 VAC	24 DVC
<b>BORE</b>	11.1				14.2				20.6				25.4				31.8				38.1				51.1			
<b>D</b>	136.2	136.2	136.2	148.0	136.2	136.2	136.2	148.0	136.2	136.2	136.2	148.0	148.0	148.0	148.0	148.0	148.0	148.0	148.0	148.0	148.0	148.0	148.0	148.0	148.0	148.0	148.0	148.0
<b>I</b>	146.5	146.5	146.5	193.8	146.5	146.5	146.5	193.0	150.5	150.5	150.5	197.0	200.0	200.0	200.0	200.0	204.0	204.0	204.0	204.0	211.3	211.3	211.3	211.3	274.3	274.3	274.3	274.3
<b>L</b>	66.0				71.1				94.0				108.0				115.5				128.0				151.1			