

Fig No:EL-314

1/2" ~ 2" (DN 15~ DN 50)



Valve Specification :

Design specification according to EN 12516-3

L-Port / T-Port / LL-Port , Four Seat design

Material : Stainless Steel, Carbon Steel or Special Alloy upon request

Blow-out-proof stem design , Anti-static design

Autuator mounting shall be in accordance with ISO 5211

End Connection: Threaded / Socket Weld / Butt Weld / Flanged

Working Pressure (CWP) : 1000 Psi

Temperature Range : -4 to 356 °F (-20 to 180 °C)

Pressure Test According to API 598

Shell test by water : 1500 Psi

Closure seat by Air : 80 ~ 100 Psi

PORT TYPE \	1	2	3	4
L	1 3 2	1 3 2	1 3 2	1 3 2
T	1 3 2	1 3 2	1 3 2	1 3 2

MATERIALS LIST

NO	PART NAME	MATERIAL	Q'TY
1	BODY	ASTM A351 GR. CF8M	1
2	BALL	ASTM A351 GR. CF8M	1
3	END CAP	ASTM A351 GR. CF8M	3
4	BODY SEAL	PTFE.	3
5	STEM	SS316	1
6	FOLLOWER	SS304	1
7	STEM PACKING	PTFE.	1 SET
9	SEAT	PTFE.	4
10	THRUST WASHER	PTFE.	1
10	STEM NUT	SS304	1
19	BOLT NUT	SS304	4~12
20-1	END CAP BOLT	SS304	4~12
20-2	BOLT	SS304	4
21	BEVELILLE WASHER	SS301	1 SET
29	BOLT WASHER	SS304	4~12
40	ELECTRIC ACTUATOR	NYLON	1

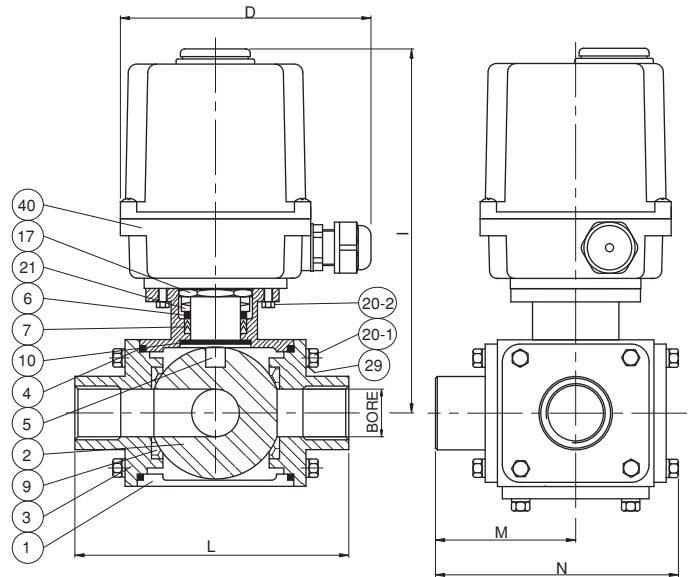

DIMENSIONS

Unit:mm

SIZE	1/2"				3/4"				1"				1-1/4"				1-1/2"				2"			
ELECTRIC FIG.	UMS		UM-1		UMS		UM-1		UM-1				UM-2		UM-1		UM-3		UM-2		UM-3			
VOLTAGE	110 VAC	220 VAC	24 VAC	24 DVC	110 VAC	220 VAC	24 VAC	24 DVC	110 VAC	220 VAC	24 VAC	24 DVC	110 VAC	220 VAC	24 VAC	24 DVC	110 VAC	220 VAC	24 VAC	24 DVC	110 VAC	220 VAC	24 VAC	24 DVC
BORE	16.0				20.0				25.0				32.0				38.0				50.0			
D	136.2	136.2	136.2	148.0	136.2	136.2	136.2	148.0	148.0	148.0	148.0	148.0	148.0	148.0	148.0	148.0	200.0	200.0	148.0	148.0	200.0	200.0	200.0	200.0
I	163.7	163.7	163.7	210.2	175.7	175.7	175.7	222.2	247.0	247.0	247.0	247.0	283.9	242.9	242.9	242.9	273.5	273.5	293.5	293.5	290.7	290.7	290.7	290.7
L	96.0				107.0				126.0				133.0				151.0				166.0			
M	48.0				53.5				63.0				66.5				75.5				83.0			
N	90.0				99.5				120.0				127.0				146.0				159.5			