

Fig No:EL-355A

1/2" ~ 2-1/2" (DN 15 ~ DN 65)



Valve Specification :

Design Specification According to ANSI B16.34

Material : Stainless Steel, Carbon Steel or Special Alloy upon request
 Blow-out-proof stem design & Anti-static design
 Stem packing to comply with **TA-Luft** requirements
 Actuator mounting shall be in accordance with ISO 5211
 In-Line Maintenance
 End Connection: Threaded / Socket Weld / Butt Weld
 Working Pressure : 1/2" ~ 1" 2000 Psi / 1-1/4" ~ 2" 1500 Psi
 Temperature Range : -4 to 356 °F (-20 to 180 °C)
 Pressure Test According to API 598
 Shell test by water : 1/2" ~ 1" 3000 Psi / 1-1/4" ~ 2" 2250 Psi

MATERIALS LIST

NO	PART NAME	MATERIAL	Q'TY
1	BODY	ASTM A351 GR. CF8M	1
2	BALL	ASTM A351 GR. CF8M	1
3	END CAP	ASTM A351 GR. CF8M	2
4	BODY SEAL	PTFE.	2
5	STEM	SS316	1
6	FOLLOWER	SS304	1
7	STEM PACKING	PTFE.	1 SET
9	SEAT	PTFE.	2
10	THRUST WASHER	PTFE.+15%G.F.	1
17	STEM NUT	SS304	1
18	TAB WASHER	SS304	1
19	BOLT NUT	SS304	4~12
20-1	END CAP BOLT	SS304	4~12
20-2	BOLT	SS304	4
21	BEVELILLE WASHER	SS301	1 SET
29	BOLT WASHER	SS304	4~12
40	ELECTRIC ACTUATOR	NYLON	1

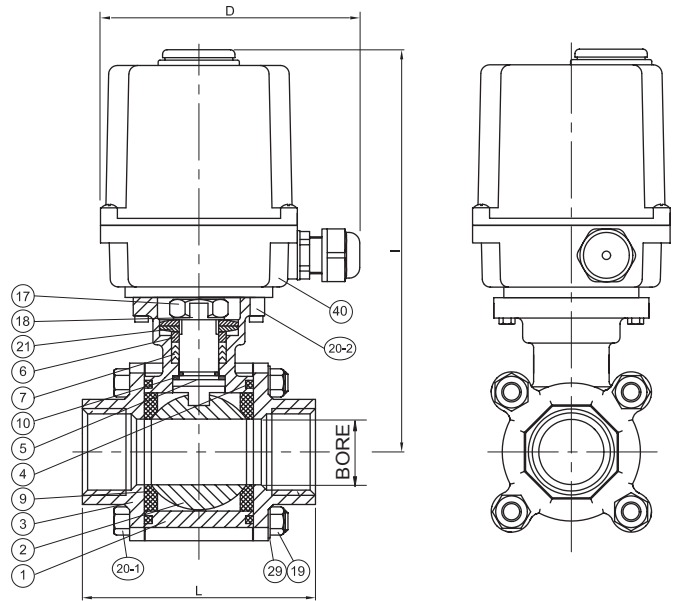

DIMENSIONS

Unit:mm

SIZE	1/2"				3/4"				1"				1-1/4"				1-1/2"				2"				2-1/2"							
	UMS		UM-1		UMS		UM-1		UMS		UM-1		UM-1		UM-1		UM-1		UM-1		UM-1		UM-2									
VOLTAGE	110 VAC	220 VAC	24 VAC	24 DVC	110 VAC	220 VAC	24 VAC	24 DVC	110 VAC	220 VAC	24 VAC	24 DVC	110 VAC	220 VAC	24 VAC	24 DVC	110 VAC	220 VAC	24 VAC	24 DVC	110 VAC	220 VAC	24 VAC	24 DVC	110 VAC	220 VAC	24 VAC	24 DVC				
	BORE				12.6				15.0				20.0				25.0				32.0				40.0				50.0			
D	136.2	136.2	136.2	148.0	136.2	136.2	136.2	148.0	136.2	136.2	136.2	148.0	148.0	148.0	148.0	148.0	148.0	148.0	148.0	148.0	148.0	148.0	148.0	148.0	148.0	148.0	148.0	148.0	148.0	148.0	148.0	148.0
I	159.7	159.7	159.7	206.2	159.7	159.7	159.7	206.2	164.4	164.4	164.4	210.9	223.3	223.3	223.3	223.3	226.6	226.6	226.6	226.6	243.0	243.0	243.0	243.0	272.7	272.7	272.7	272.7	272.7	272.7	272.7	272.7
L	75.0				72.5				85.4				105.3				111.0				127.3				142.8							