

serie **EUROFLY**

Art. **600000**

**BREVETTATA
PATENTED**



- Valvola a farfalla in ottone a passaggio totale, filettatura F/F con sistema di regolazione del flusso.
- Brass butterfly valve full bore, F/F threaded with throttling.
- Vanne à papillon en laiton taraudée F/F avec système de réglage d'écoulement.
- Absperkklappe aus Messing, beiderseits Innengewinde mit Durchflussregler.
- Válvula mariposa en latón, roscas hembra / hembra con sistema de regulación del flujo.

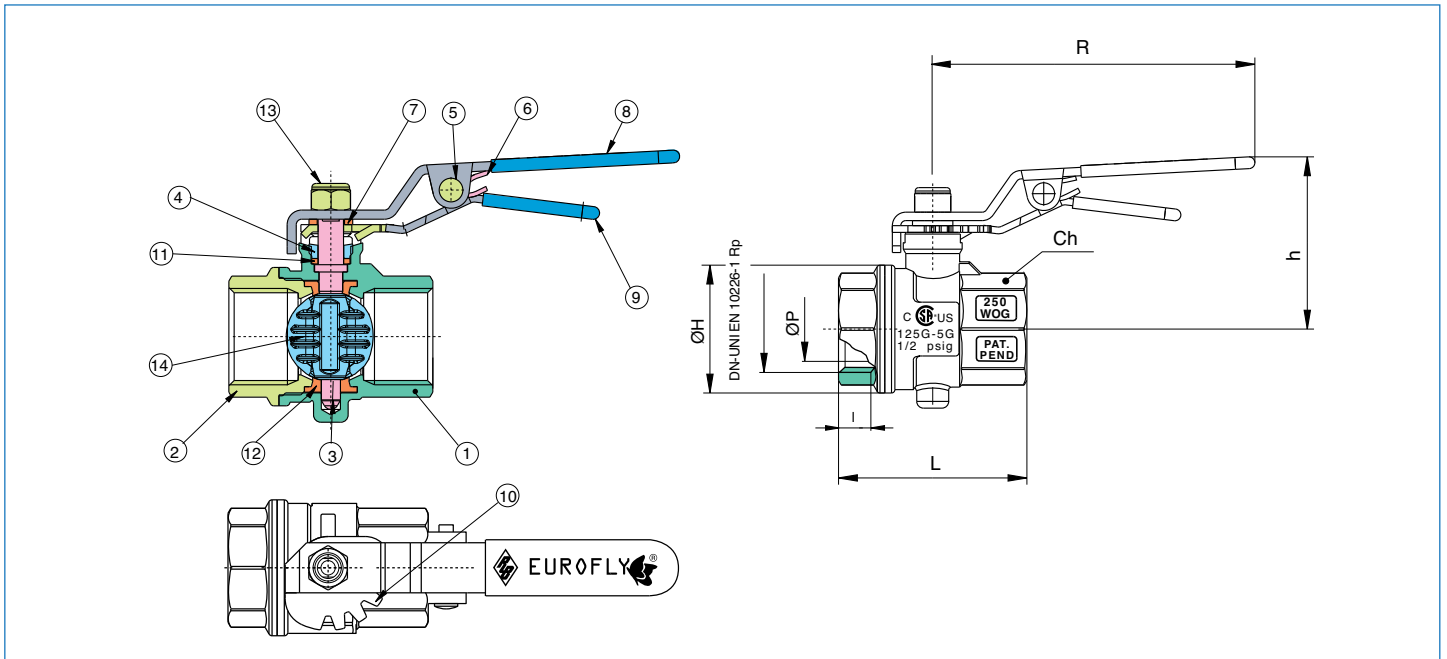

POS.	DENOMINAZIONE	PART NAME	DESCRIPTION	TEILBENENNUNG	DENOMINACION	MATERIALE-MATERIALS MATERIAUX-WERKSTOFF- MATERIAL	N°P
1	CORPO	BODY	CORPS	GEHÄUSE	CUERPO	OTTONE CW617N UNI EN 12165	1
2	MANICOTTO	END CONNECTION	MANCHON	MUFFE	MANGUITO	OTTONE CW617N UNI EN 12165	1
3	ASTA	STEM	TIGE	EJE	EJE	OTTONE CW614N UNI EN 12164	1
4	GHIERA	WASHER	EMBOUT	RING	ANILLO ROSCADO	OTTONE CW614N UNI EN 12164	1
5	SPINA	LOCK PIN	PRISE	STIFT	ESPINA	ACCIAIO	1
6	MOLLA	SPRING	RESSORT	FEDER	RESORTE	ACCIAIO PER MOLLE	1
7	GUARNIZIONE ANTIATT.ASTA	ANTIFRICTION SEAT	JOINT ANTI-FRICTION	STOßHEMMENDE DICHTUNG	ASINTO CONTRA FRICCIÓN EJE	PTFE CARICATO GRAFITE	1
8	LEVA	HANDLE	POIGNÉE	HANDHEBEL	PALANCA	ACCIAIO DD11 UNI EN 10111	1
9	LEVA	HANDLE	POIGNÉE	HANDHEBEL	PALANCA	ACCIAIO UNI EN 10111	1
10	FERMO MANOVRA	HALF TURN STOP	ARRÊT DE MANOEUVRE	ANSCHLAG	PARO MANIOBRRA	ACCIAIO UNI EN 10111	1
11	GUARNIZIONE ASTA	STEM SEAL	JOINT DE L'AXE	SPINDELDICHTUNG	JUNTA EJE	PTFE	1
12	GUARNIZIONE FARFALLA	SEAT	JOINT DU PAPILLON	MANSCHETTE	ASIENTO MARIPOSA	EPDM	1
13	DADO	NUT	ECROU	MUTTER	TUERCA	ACCIAIO CL 04	1
14	LENTE	DISC	PAPILLON	KLAPPE	LENTE	PEI (ULTEM 1000)	1

MISURA SIZE	DN	€	BOX	MASTER BOX	I	Ch	ØH	L	h	R	Kv	PN	Kg	
1/2"	15	8,53	50	100	16	15	25	31	48,5	46,5	95	8,5	16	0,19
3/4"	20	10,18	25	50	21	16,3	31	38	56	50,5	95	17	16	0,25
1"	25	13,31	20	40	27	19,1	38	46	64	54	95	27	16	0,36
1 1/4"	32	20,98	12	24	34	21,4	48	55,5	76	71,5	120	50	16	0,67
1 1/2"	40	27,62	10	20	41	21,4	54	65,5	82	76,5	120	82,5	16	0,88
2"	50	37,60	4	8	52	25,7	67	77,5	93	86,5	150	136,5	16	1,31
2 1/2"	65	130,57	2	4	65	30,2	90	102	112	121	205	240	16	3,06
3"	80	168,70	-	4	80	33,3	105	122	129,5	131,5	205	340	16	4,67
4"	100	220,63	-	2	103	39,3	130	145	146	145	205	550	16	6,29

Limiti di temperatura: -10°C + 130°C - Temperature range: -10°C + 130°C.



Art. 600009 A RICHIESTA - ON REQUEST - SUR DEMANDE BREVETTATA PATENTED AUF ANFRAGE - A PREGUNTA

- Valvola a farfalla in ottone a passaggio totale filettatura F/F, con sistema di regolazione del flusso e guarnizione in VITON®.
- Brass butterfly valve full bore F/F threaded with throttling and VITON® seal.
- Vanne à papillon en laiton taraudée F/F, avec système de réglage d'écoulement, joint an VITON®.
- Absperrklappe aus Messing, beiderseits Innengewinde mit Durchflussegler und VITON® Dichtung.
- Válvula mariposa en latón, roscas hembra / hembra con sistema de regulación del flujo y asiento en VITON®.

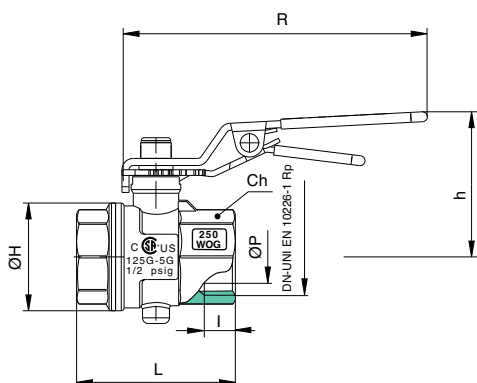

MISURA SIZE	DN	€	BOX	MASTER BOX	ØP	I	Ch	ØH	L	h	R	Kv	PN	Kg
1/2"	15	10,61	50	100	16	15	25	31	48,5	46,5	95	8,5	16	0,19
3/4"	20	12,84	25	50	21	16,3	31	38	56	50,5	95	17	16	0,25
1"	25	16,36	20	40	27	19,1	38	46	64	54	95	27	16	0,36
1"1/4	32	26,29	12	24	34	21,4	48	55,5	76	71,5	120	50	16	0,67
1"1/2	40	36,98	10	20	41	21,4	54	65,5	82	76,5	120	82,5	16	0,88
2"	50	52,15	4	8	52	25,7	67	77,5	93	86,5	150	136,5	16	1,31

Limiti di temperatura: -10°C + 150°C - Temperature range: -10°C + 150°C.



Art. 600300 BREVETTATA PATENTED

- Valvola a farfalla in ottone a passaggio totale filettatura M/F con sistema di regolazione del flusso.
- Brass butterfly valve full bore M/F threaded with throttling.
- Vanne à papillon en laiton taraudée M/F avec système de réglage d'écoulement.
- Absperrklappe aus Messing Innen-/Außengewinde und Durchflussegler.
- Válvula mariposa en latón, roscas macho / hembra con con sistema de regulación del flujo.

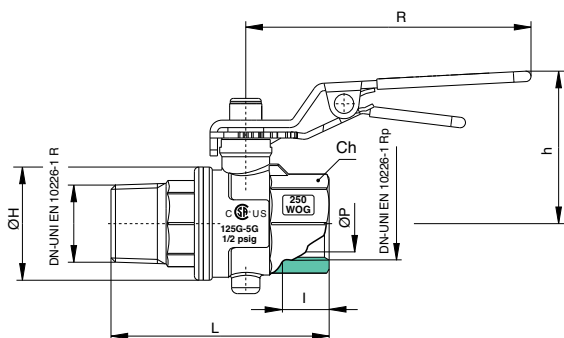

MISURA SIZE	DN	€	BOX	MASTER BOX	ØP	I	Ch	ØH	L	h	R	Kv	PN	Kg
1/2"	15	9,21	50	100	16	15	25	31	63,5	46,5	95	8,5	16	0,22
3/4"	20	11,16	25	50	21	16,3	31	38	73	55	95	17	16	0,30
1"	25	14,69	20	40	27	19,1	38	46	82,5	54	95	27	16	0,44
1"1/4	32	25,14	10	20	34	21,4	48	55,5	100	71,5	120	50	16	0,81
1"1/2	40	30,45	6	12	41	21,4	54	65,5	104	76,5	120	82,5	16	1,02
2"	50	44,92	4	8	52	25,7	67	77,5	119,5	86,5	150	136,5	16	1,53

Limiti di temperatura: -10°C + 130°C - Temperature range: -10°C + 130°C.



Art. 600600

**BREVETTATA
PATENTED**

- Valvola a farfalla in ottone a passaggio totale filettatura F/F con sistema di regolazione del flusso, per impianti di isolamento termico.
- Brass butterfly valve full bore F/F threaded with throttling suitable for thermic insulated plants.
- Vanne à papillon en laiton taraudée F/F avec système de réglage d'écoulement pour isolation thermique.
- Absperrklappe aus Messing, beiderseits Innengewinde mit Durchflussregler geeignet für isolierte Rohrleitungen.
- Válvula mariposa en latón, roscas hembra / hembra, con sistema de regulación del flujo, por instalaciones de aislamiento térmico.

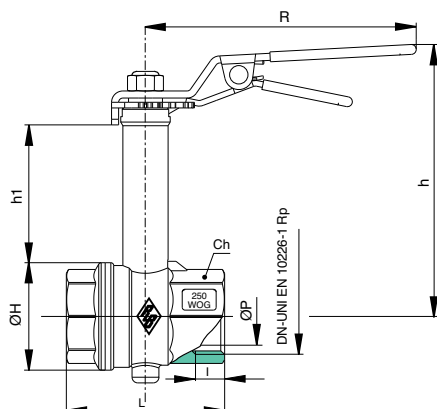

MISURA SIZE	DN	€	BOX	MASTER BOX	ØP	I	Ch	ØH	L	h	h1	R	Kv	PN	Kg
1/2"	15	15,27	25	50	16	15	25	31	48,5	91,5	48	95	8,5	16	0,25
3/4"	20	16,19	20	40	21	16,3	31	38	56	95,5	48	95	17	16	0,32
1"	25	19,41	15	30	27	19,1	38	46	64	99	48	95	27	16	0,41
1"1/4	32	32,31	6	12	34	21,4	48	55,5	76	126,5	60	120	50	16	0,76
1"1/2	40	41,39	4	8	41	21,4	54	65,5	82	131,5	60	120	82,5	16	0,99
2"	50	61,33	2	4	52	25,7	67	77,5	93	156,5	74,5	150	136,5	16	1,55

Limiti di temperatura: -10°C + 130°C - Temperature range: -10°C + 130°C.



Art. 600001

**BREVETTATA
PATENTED**

- Valvola a farfalla in ottone, a passaggio totale, filettatura F/F con sistema di regolazione del flusso.
- Brass butterfly valve full bore F/F threaded with throttling.
- Vanne à papillon en laiton taraudée F/F avec système de réglage d'écoulement.
- Absperrklappe aus Messing, beiderseits Innengewinde, mit Durchflussregler.
- Válvula mariposa en latón a paso total, roscas hembra / hembra con sistema de regulación del flujo.

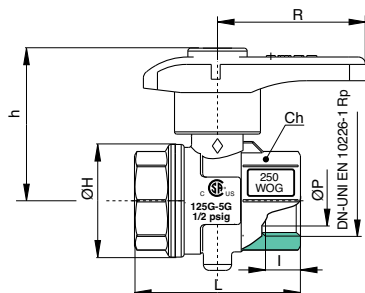





MISURA SIZE	DN	€	BOX	MASTER BOX	ØP	I	Ch	ØH	L	h	R	Kv	PN	Kg
1/2"	15	7,48	50	100	16	15	25	31	48,5	48	50	8,5	16	0,17
3/4"	20	9,19	25	50	21	16,3	31	38	56	51,5	50	17	16	0,24
1"	25	11,70	20	40	27	19,1	38	46	64	55	50	27	16	0,35

Limiti di temperatura: -10°C + 130°C - Temperature range: -10°C + 130°C

Art. 600301

BREVETTATA
PATENTED

-  Valvola a farfalla in ottone a passaggio totale, filettatura M/F, con sistema di regolazione del flusso.
-  Brass butterfly valve full bore, M/F threaded with throttling.
-  Vanne à papillon en laiton taraudée M/F avec système de réglage d'écoulement.
-  Absperrklappe aus Messing Innen-/Außengewinde mit Durchflussregler.
-  Válvula mariposa en latón a paso total, roscas macho / hembra con con sistema de regulación del flujo.



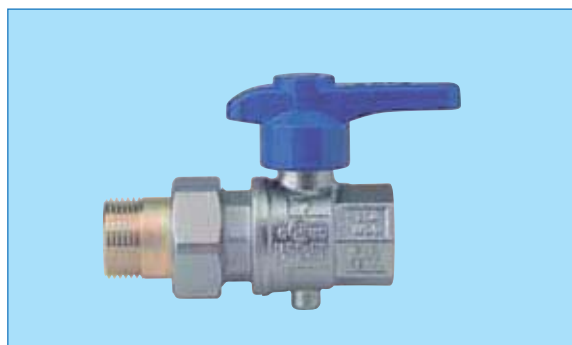
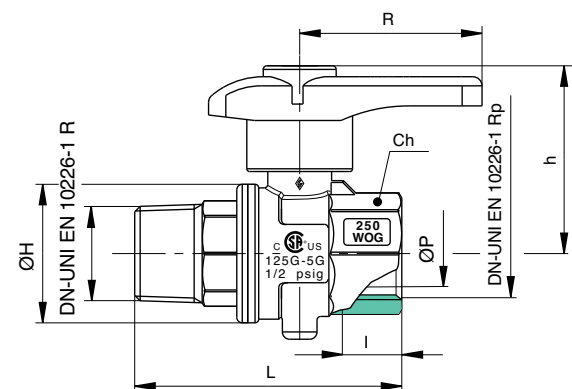
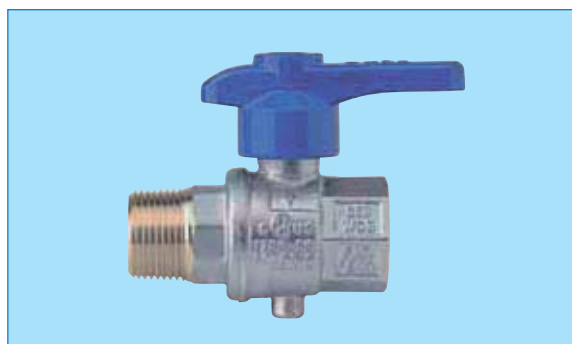

MISURA SIZE	DN	€	BOX	MASTER BOX	ØP	I	Ch	ØH	L	h	R	Kv	PN	Kg
1/2"	15	8,06	50	100	16	15	25	31	63,5	48	50	8,5	16	0,20
3/4"	20	10,07	25	50	21	16,3	31	38	73,2	51,5	50	17	16	0,28
1"	25	13,47	20	40	27	19,1	38	46	82,5	55	50	27	16	0,41

Limiti di temperatura: -10°C + 130°C - Temperature range: -10°C + 130°C.



Art. 600500

BREVETTATA
PATENTED

-  Valvola a farfalla in ottone a passaggio totale filettatura femmina, raccordo per collettori con sistema di regolazione del flusso.
-  Brass butterfly valve full bore, female threaded and fitting for manifold with throttling.
-  Vanne à papillon en laiton taraudée femelle, raccord pour collecteur, avec système de réglage d'écoulement.
-  Absperrklappe aus Messing, Innengewinde, mit Verschraubungsanschluss und Durchflussregler.
-  Válvula mariposa en latón a paso total, rosca hembra / conexión por colectores, con sistema de regulación del flujo.

MISURA SIZE	DN	€	BOX	MASTER BOX	ØP	I	I1	Ch	ØH	L	h	R	Kv	PN	Kg
1/2"	15	10,40	40	80	16	15	10	25	31	80,5	48	50	8,5	16	0,26
3/4"	20	13,88	20	40	21	16,3	12	31	38	91	51,5	50	17	16	0,38
1"	25	19,67	15	30	27	19,1	14	38	46	103,5	55	50	27	16	0,60

Limiti di temperatura: -10°C + 130°C - Temperature range: -10°C + 130°C.

Disponibile accessorio, Art. 6404, a pag. 252 - The accessory, item 6404, is available. See at page 252.

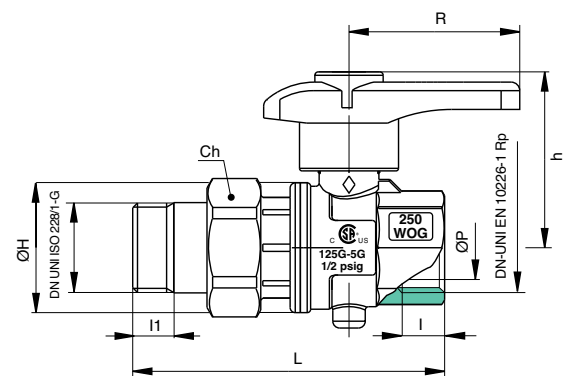

serie **FLY**
Art. **600700**

BREVETTATA
PATENTED



- Valvola a farfalla in ottone a passaggio totale per erogazione con portagomma e sistema di regolazione del flusso.
- Brass butterfly bib-cock valve full bore, with hose tail and throttling.
- Vanne à papillon en laiton pour arrosage, avec porte caoutchouc et système de réglage d'écoulement.
- Auslaufabsperklappe aus Messing, mit Schlauchtülle und Durchflussregler.
- Válvula mariposa en latón por derogación con porta manguera y sistema de regulación del flujo.

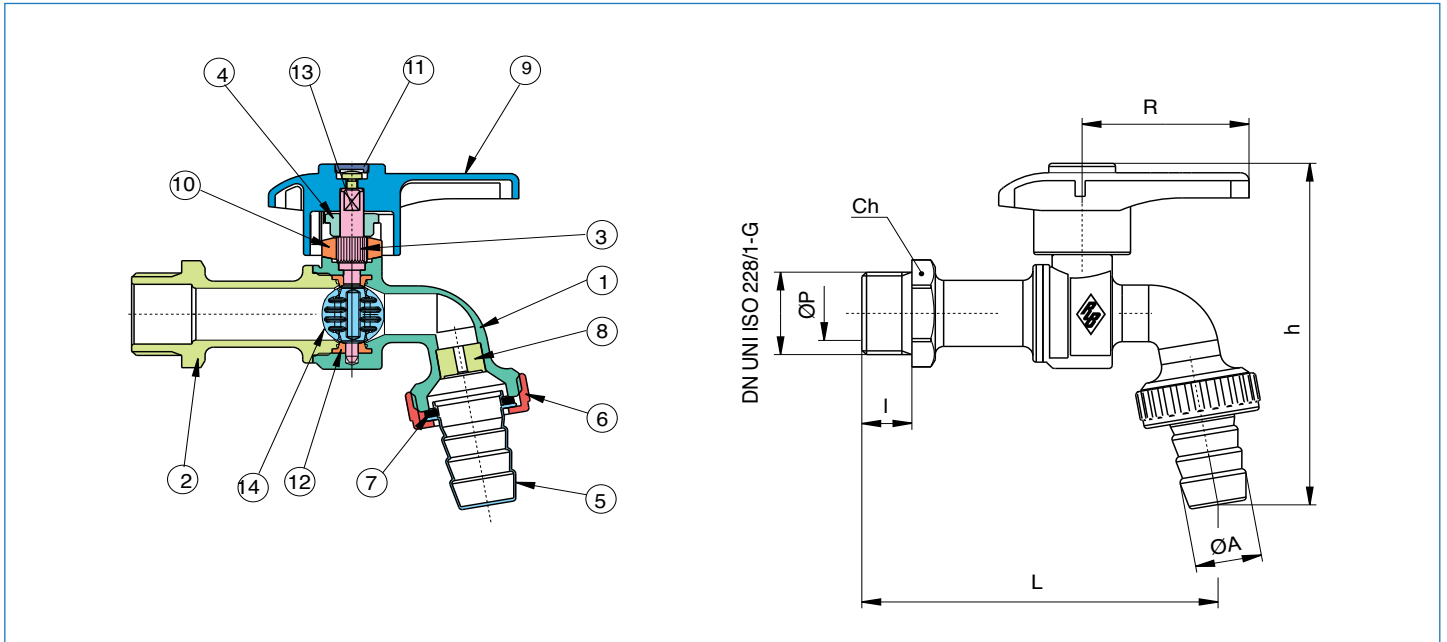

POS.	DENOMINAZIONE	PART NAME	DESCRIPTION	TEILBENENNUNG	DENOMINACION	MATERIALE-MATERIALS MATERIAUX-WERKSTOFF- MATERIAL	N°P
1	CORPO	BODY	CORPS	GEHÄUSE	CUERPO	OTTONE CW617N UNI EN 12165	1
2	MANICOTTO	END CONNECTION	MANCHON	MUFFE	MANGUITO	OTTONE CW617N UNI EN 12165	1
3	ASTA	STEM	TIGE	EJE	EJE	OTTONE CW614N UNI EN 12164	1
4	GHIERA	WASHER	EMBOUT	RING	ANILLO ROSCADO	OTTONE CW614N UNI EN 12164	1
5	PORTAGOMMA	HOSE TAIL	PORTE CAOUTCHOUC	SCHLAUCHTÜLLE	PORTAGOMA	OTTONE CW617N UNI EN 12165	1
6	GIRELLO	NUT	ECROU	VERSCHRAUBRING	DADO	OTTONE CW617N UNI EN 12165	1
7	GUARNIZIONE PIANA	FLAT SEAT	JOINT PLAT	FLACHE DICHTUNG	ASIEN TO PLANO	PVC	1
8	ROMPIGETTO	SPRAY NOZZLE	BRISE JET	SIEB	MANGUERA	HDPE	1
9	LEVA	HANDLE	POIGNÉE	HANDEBEL	PALANCA	ALLUMINIO EN-AC 46100 EN 1706	1
10	FERMO MANOVRA	HALF TURN STOP	ARRÊT DE MANOEUVRE	ANSCHLAG	PARO MANIOBRA	POM	1
11	TAPPO	CAP	BOUCHON	PFROPFEN	TAPON	ABS	1
12	GUARNIZIONE FARFALLA	SEAT	JOINT DU PAPILLON	MANSCHETTE	ASIEN TO MARIPOSA	NBR	1
13	VITE	SCREW	VIS	SCHRAUBE	TORNILLO	FERRO	1
14	LENTE	DISC	PAPILLON	KLAPPE	LENTE	PEI (ULTEM 1000)	1





MISURA SIZE	DN	€	BOX	MASTER BOX	ØP	I	Ch	L	ØA	h	R	PN	Kg
1/2"	15	11,12	25	50	12	12	25	78,5	15,5	96,5	50	16	0,24
3/4"	20	14,18	15	30	16,5	15	30	91,5	20,5	108,5	50	16	0,34
1"	25	21,62	10	20	18	18	38	100	25,5	123	50	16	0,51

Limiti di temperatura: -10°C + 100°C - Temperature range: -10°C + 100°C.

Disponibile accessorio, Art. 5810, a pag. 250 - The accessory, item 5810, is available. See at page 250.

Art. 600760

**BREVETTATA
PATENTED**

-  Valvola a farfalla in ottone a passaggio totale per erogazione con portagomma e sistema di regolazione del flusso con serratura.
-  Brass butterfly bib-cock, full bore, with hose tail and lockable throttling.
-  Vanne à papillon en laiton à passage totale pour arrosage avec porte-tuyau et système de réglage découlement avec serrure.
-  Auslaufabsperriklappe aus Messing, mit Schlauchtülle und mit abschliessbarem Druchflussregler.
-  Válvula mariposa en latón a paso total por erogación con porta goma y sistema de regulación del flujo con cerradura.

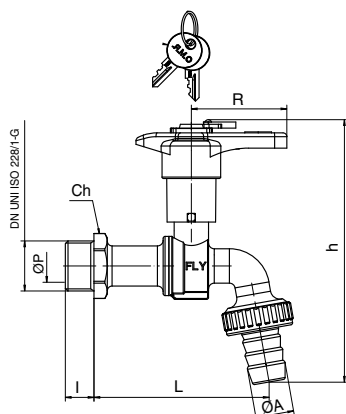

MISURA SIZE	DN	€	BOX	MASTER BOX	ØP	I	ØA	Ch	L	h	R	PN	Kg
1/2"	15	31,10	25	50	12	12	15,5	25	78,5	125,5	50	16	0,39
3/4"	20	33,55	10	20	16,5	15	20,5	30	91,5	137,5	50	16	0,42
1"	25	42,67	8	16	18	18	25,5	38	100	151,5	50	16	0,57

Limiti di temperatura: -20°C +100°C - Temperature range: -20°C +100°C.

Disponibile accessorio, Art. 580900KR, a pag. 253 - The accessory, item 580900KR, is available. See at page 253.