



Butterfly Valves SBP Series

are ideally suited for Shut-off, Flow Control and Throttling of corrosive and abrasive process media in either liquid, powdery or gaseous state.

Modular Design

Butterfly Valves SBP Series are available as DIN- or ANSI-Valves, with bare shaft as per standard. Valves can be delivered as complete units, i.e. with mounted-on locking handles, manual gearboxes or with quarter turn pneumatic actuators double- or single-acting.

The sturdy design bodies are made of cast steel 1.0619 (WCB), coating RAL 5005 signal-blue or stainless steel casting 1.4408 (CF-8M), with resistant liners such as PTFE, PTFE-AS (anti-static), PTFE-T (mod.) or UHMWPE.



Main Features

- Heavy-duty, compact construction, maintenance-free
- Bubble-tight shut-off throughout the full pressure and temperature range
- Wide selection of high-quality liner and disc materials for economical valve performance
- Unique shaft sealing arrangement assures maintenance-free operation at automated processes and high operating pressures, optimized and reinforced liner shape
- No need of additional flange gaskets due to wide and chambered flange sealing surface
- One-piece disc/shaft for hysteresis-free flow control, with polished sealing surface leading to low torque values
- Flange drilling acc. to DIN PN10/16 resp. ANSI 150lbs for installation into existing piping systems

 **Conformity according to European Pressure Equipment Directive 97/23/EC (PED)**

Options



Lug 1.0619 (WCB)
PTFE/PFA, locking handle



Lug 1.4408 (CF-8M)
PTFE-AS/PFA-AS, bare shaft



Wafer SS316L (1.4435)
PTFE/PFA, pneum. actuator

SBP: Technical Data

51 Butterfly Valves, plastomer-lined

PM 51 M.01 e

March 2006



Operating Conditions

- Temperature range from -40°C up to +220°C (depending on material of liner resp. encapsulation)
- Pressure range from 1 mbar up to 16 bar

Testing / Marking

- Pressure- and tightness testing acc. to EN 12266-1, leakage rate A, and spark testing at 35 kV to assure lining integrity. Marking of valves on body and name plate acc. to EN 19.
- Material- resp. test certificate acc. to EN 10204-3.1

Outline Drawing / Actuator Options

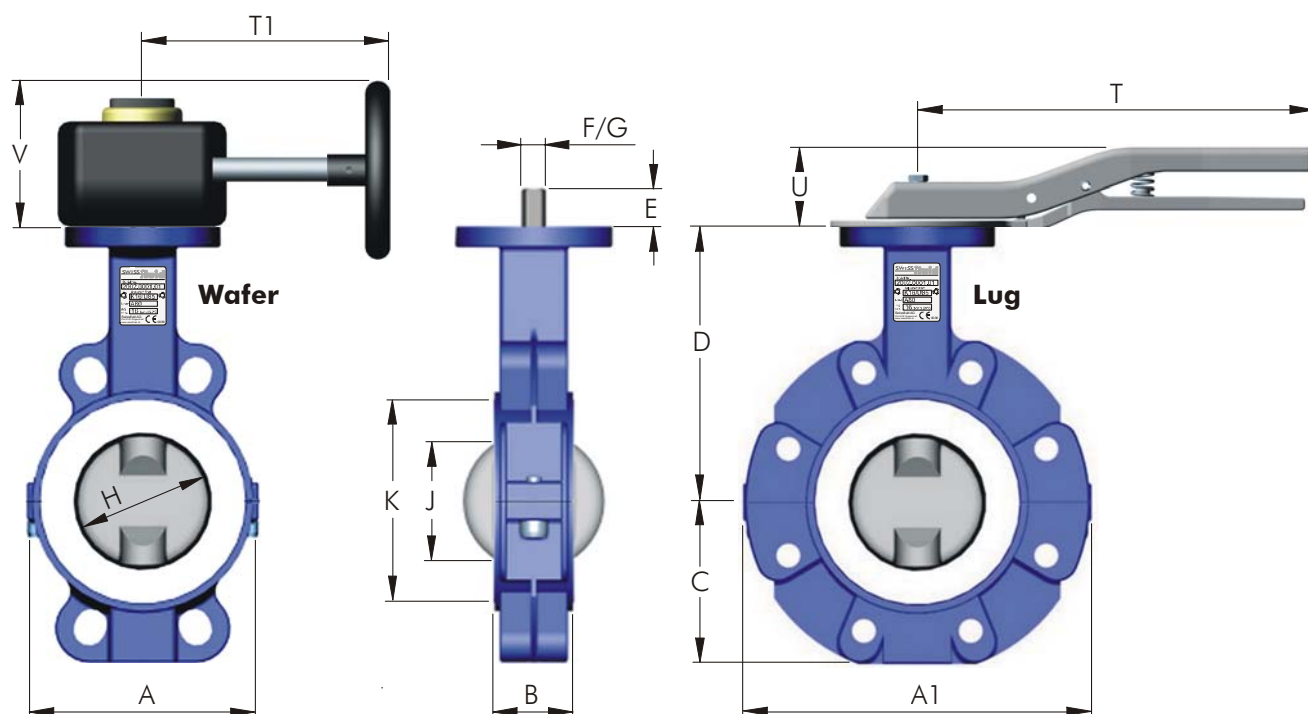

Dimensions in mm

Size DN	A	A1	B	C	D	E	F	G	H	J	K	ISO	T	T1	U	V
25/1"	-	115	33	46	87	23	14	11	35	10	64	F05	230	126	46	78
32/1¼"	-	115	33	46	87	23	14	11	35	10	64	F05	230	126	46	78
40/1½"	-	145	33	64	109	23	14	11	50	38	79	F07	230	126	46	78
50/2"	118	160	43	69	124	23	14	11	60	42	99	F07	230	126	46	78
65/2½"	-	180	46	79	144	23	14	11	60	39	104	F07	230	126	46	78
80/3"	134	202	46	93	159	23	14	11	80	66	119	F07	230	126	46	78
100/4"	162	232	52	107	184	23	18	14	100	86	144	F07	270	126	51	78
125/5"	-	269	56	119	199	23	18	14	125	112	169	F07	270	126	51	78
150/6"	248	289	56	130	209	28	24	17	150	141	199	F07	325	185	51	96
200/8"	273	349	60	158	239	28	24	17	200	191	249	F10	-	185	-	96
250/10"	328	400	68	195	264	40	30	22	250	241	309	F10	-	251	-	142
300/12"	378	470	78	229	264	40	30	22	300	290	359	F10	-	251	-	142

Face to face B acc. to DIN EN 558-1 range 20

A

B

C

D

E

F

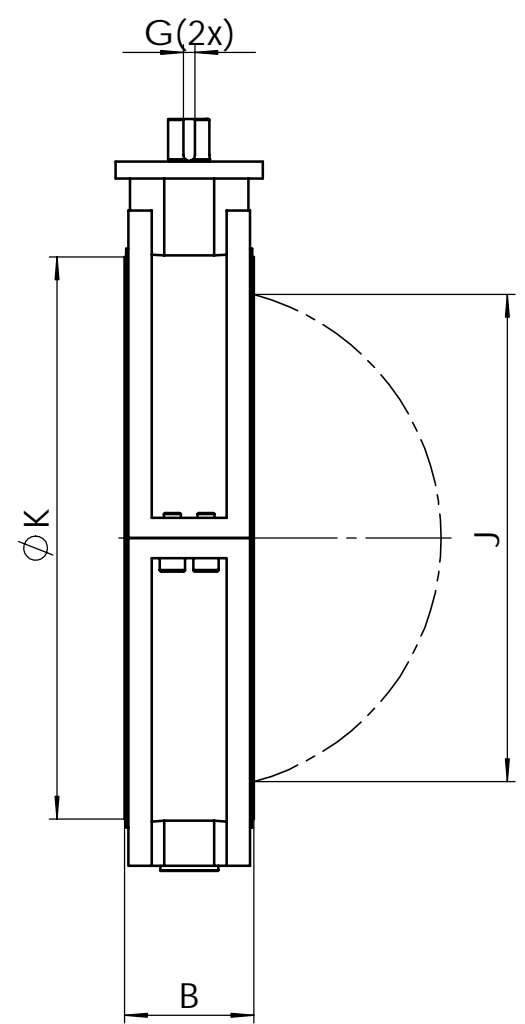
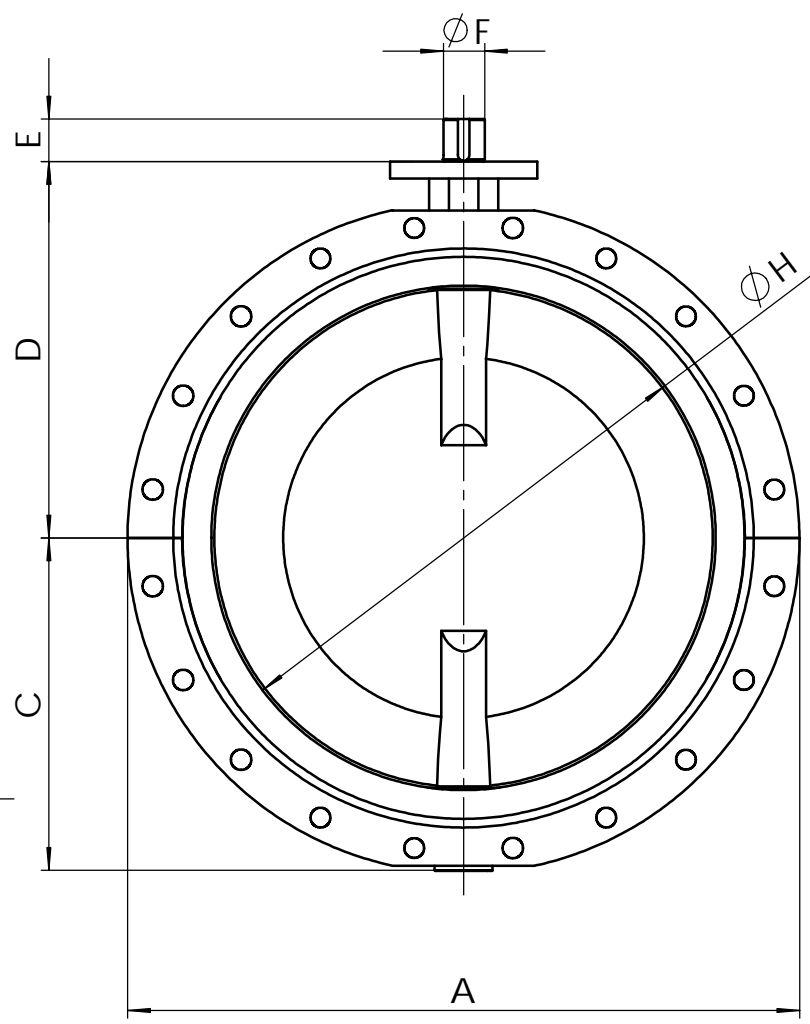

Size	DN	A	B	C	D	E	F	G	H	J	K	ISO - Flange	Cv-value	appr. Torque	appr. Weight
28"	700	1020	165	476	558	90	70	20	680	660	779	F16	41921	1760	410
30"		1110	165	526	608	90	70	20	740	721	839	F16	46849	1980	480
32"	800	1110	165	526	608	90	70	20	740	721	839	F16	46849	1980	640
36"	900	1220	203	661	685	90	90	25	880	856	980	F25	66440	2640	800
42"	1000	1420	216	754	768	90	100	28	1000	976	1100	F25	85558	3300	990

Cv values in usg/min (Kv m³/h = Cv/1.16)
 Torque values in Nm (in-lbs = Nm x 8.85)
 Weights in Kg (lbs = Kg x 2.2)
 F/F acc. to EN 558-1 Range 20

We reserve all rights in this document and the information contained therein. Reproduction, use or disclosure to third parties without express authority is strictly forbidden. © 2002 Swissfluid AG, Switzerland		General tolerance class for machined parts: Linear and angular dimensions ISO 2768 fine <input type="checkbox"/> medium <input checked="" type="checkbox"/> coarse <input type="checkbox"/>		Designed with SolidWorks		Sep. parts list same no.: <input type="checkbox"/> diff. no.: <input type="checkbox"/>		Scale:	
All dimensions in millimeters Roughness symbols according to DIN ISO1302						SWISSfluid Swissfluid AG CH-5600 Lenzburg			
Date	Name								
Drawn	02.03.05	RJ		Weight:	Butterfly Valve Lug-style DN700-1200 PN10 / 28"-48" - 150lbs				
Chk'd	02.03.05	RW		Product Group: SBP					
App'v'd									
Revision	A 11.03.05 Japello			Dwg No.		Rev.	Size: A4		
Revision	B 24.05.06 Japello			1.51.9603		C	Language: E		
Revision	C 12.09.07 Japello						Sheets: 1 Sheet No.: 1		

SBP: Construction, Mounting Options

51 Butterfly Valves, plastomer-lined

PM 51 M.02 e

March 2006



Construction of Valve

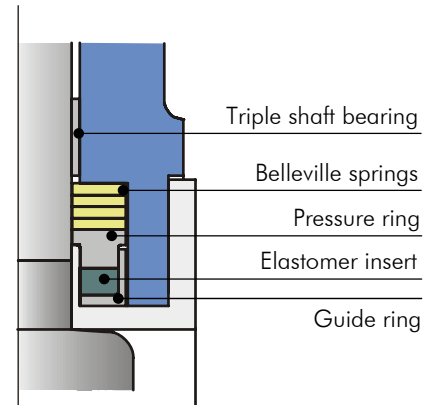
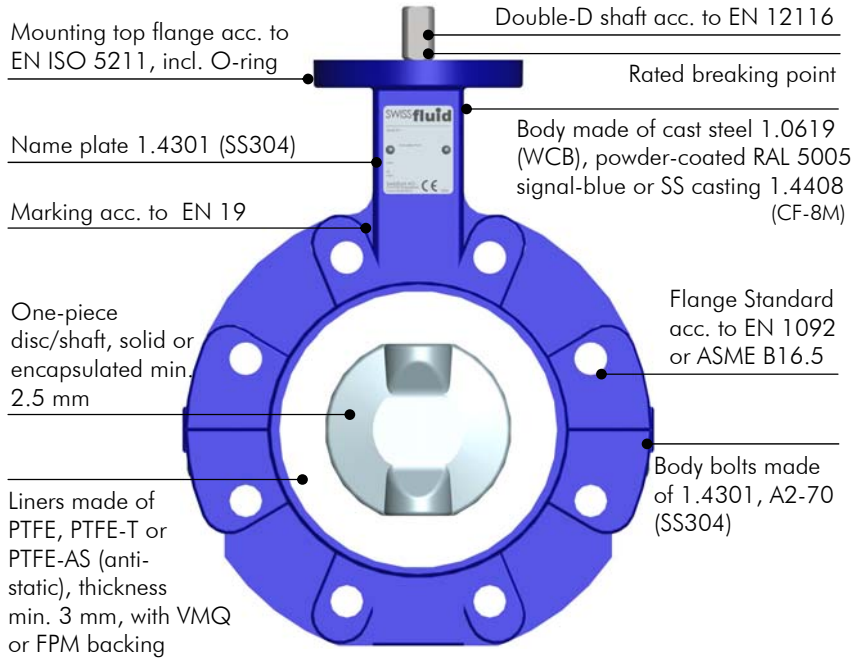

Dynamic Shaft Seal

Mounting Options

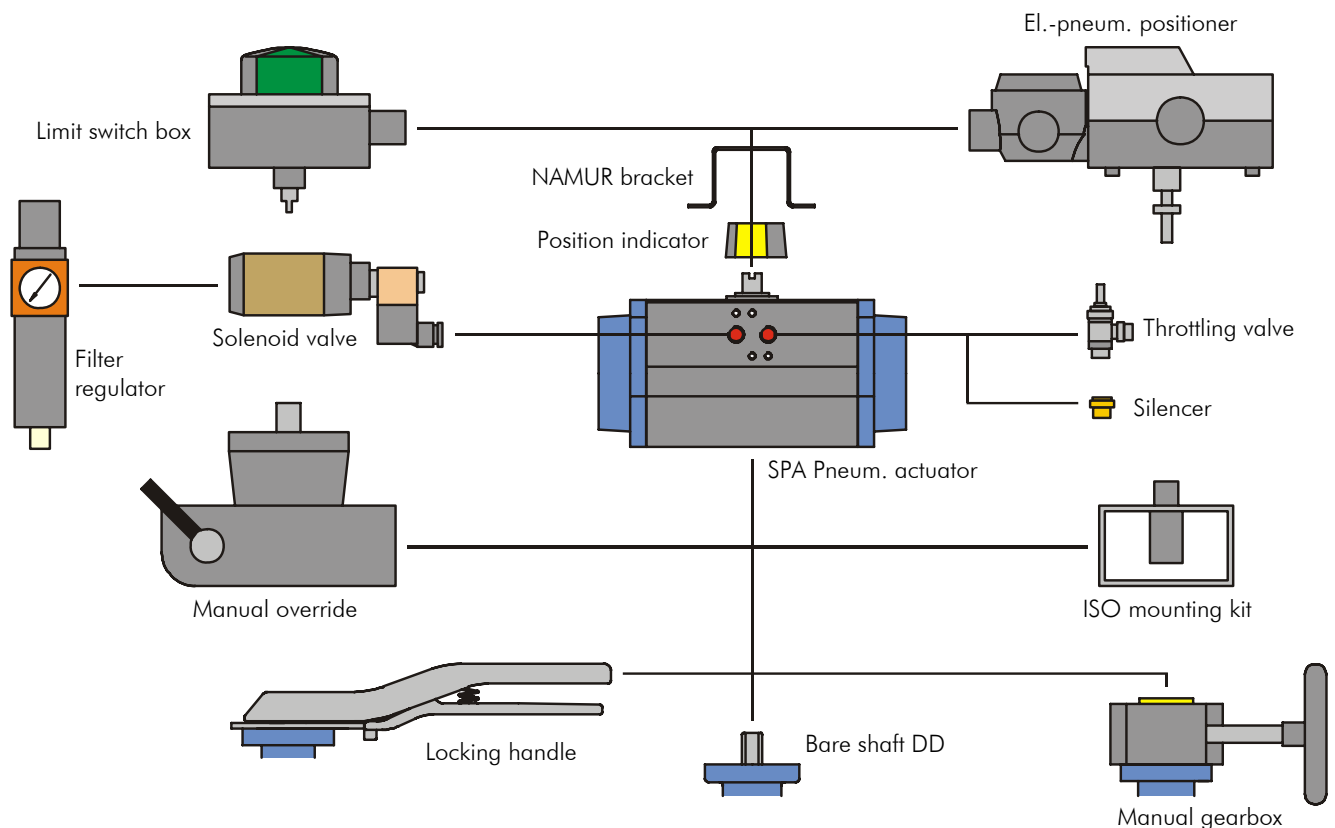



Construction

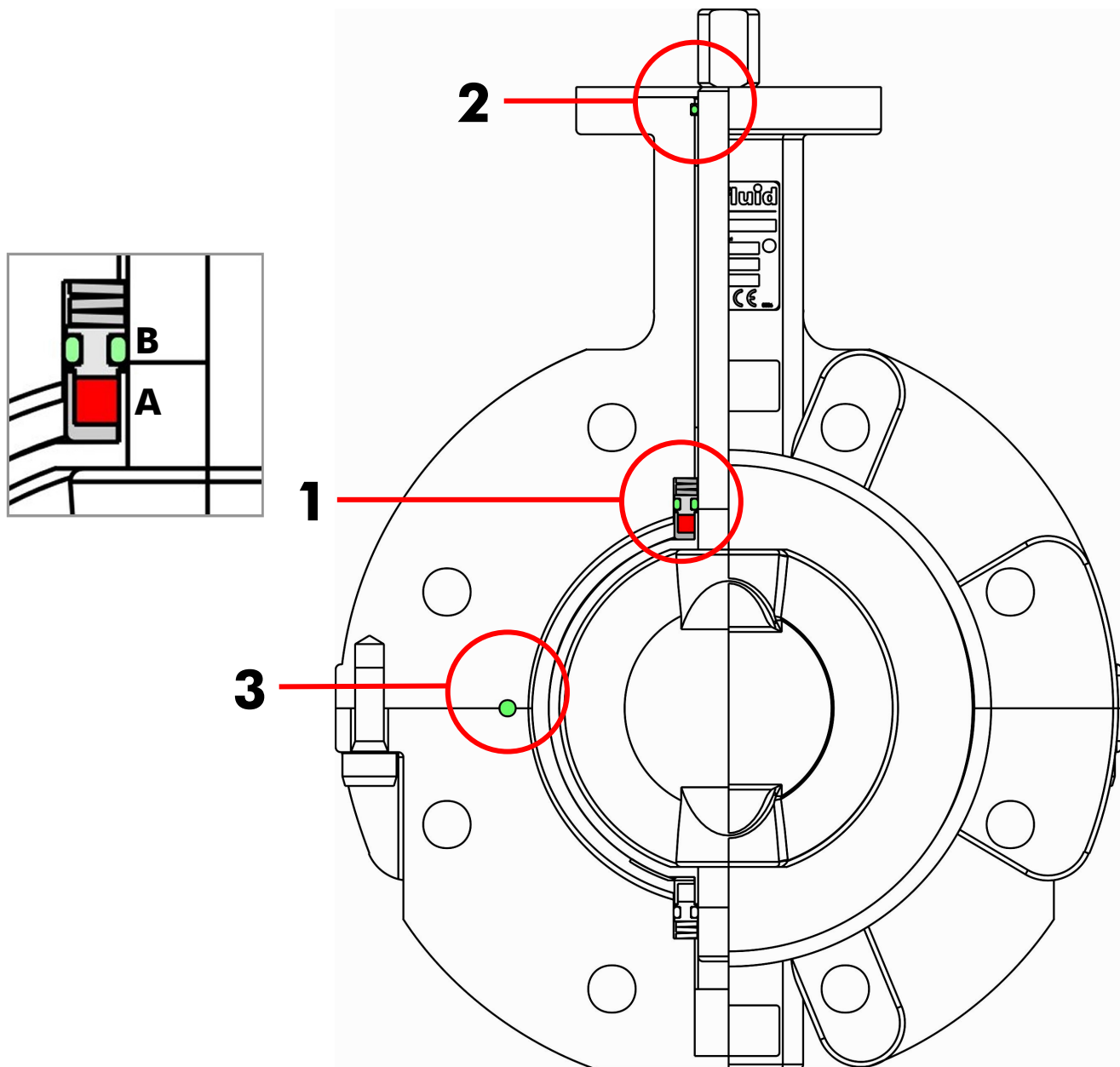

Features

- 1 Primary Seal** onto shaft, elastomer insert and double O-ring, prestressed by belleville springs
- 2 Secondary Seal** onto shaft, O-ring on atmospheric outlet
- 3 Third Seal** crossways onto body halves, elastomer round gasket

SBP: PT-Diagram, Torques, Weights

51 Butterfly Valves, plastomer-lined

PM 51 M.03 e

October 2006



Pressure-/Temperature Diagram

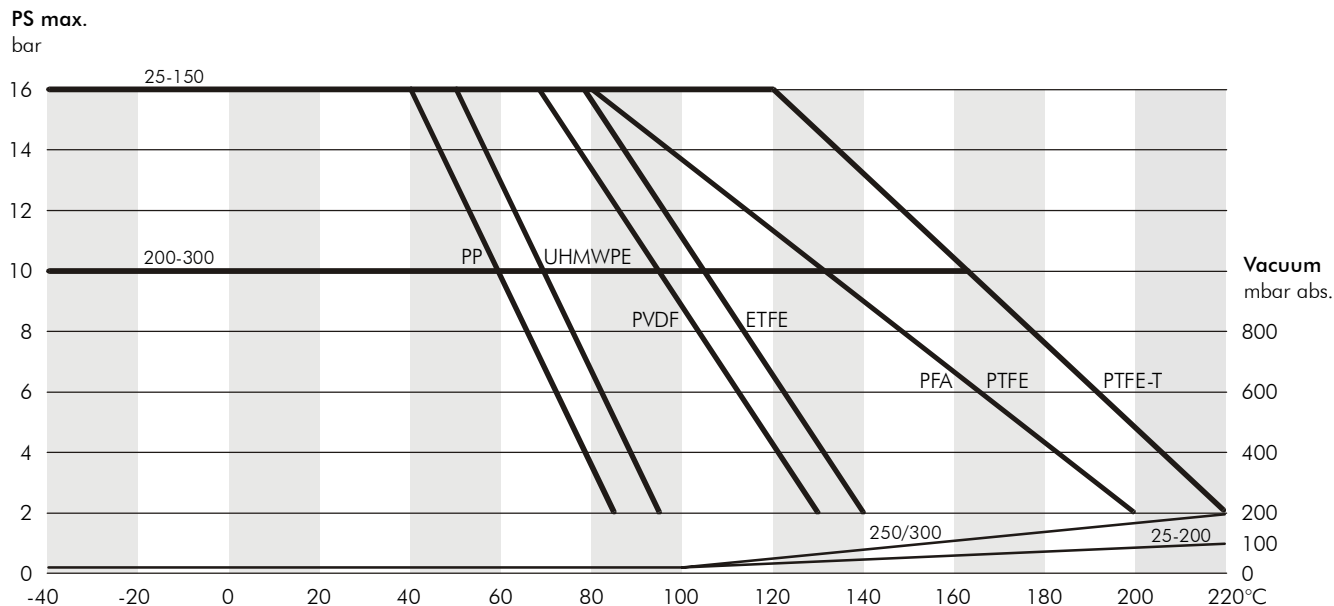

Torque Values in Nm (in-lbs = Nm x 8.85)

Torque values for PFA-encapsulated disc and specified body liner

Size DN	25/32	40	50	65	80	100	125	150	200	250	300
A80 PTFE	20	25	30	30	40	50	60	110	180	250	350
A81 PTFE-T	22	28	33	33	44	55	66	122	198	275	385
A82 PTFE-AS	20	25	30	30	40	50	60	110	180	250	350
A89 PP	32	40	45	45	60	75	90	165	270	375	525
A90 UHMWPE	28	35	40	40	52	65	78	140	230	325	455
max. allowable	145	145	145	145	145	320	320	700	700	1'200	1'200

- For liner resp. disc encapsulation never use for both the same material, otherwise considerable increase of torque values must be expected!
- Stated values to be break-away torques without any consideration of safety factors for actuators.

Weights in kg (lbs = kg x 2.2)

Figures stated for execution PTFE/PFA/bare shaft

Size DN	25/32	40	50	65	80	100	125	150	200	250	300
Lug-style body	2.3	3.2	4.7	6.0	6.5	8.5	10.6	13.9	17.9	27.2	35.9
Wafer-style body	-	-	-	-	4.3	6.3	-	10.9	16.2	24.1	31.2
Locking handle	0.9	0.9	0.90	0.9	0.9	1.2	1.2	1.5	-	-	-
Gearbox GG25	2.3	2.3	2.3	2.3	2.3	2.3	2.2	2.5	2.5	4.5	4.5

Wafer: DN25/32/40/65/125 made of Lug-style bodies with drilled-thru holes

Weights for pneumatic actuators acc. to separate data sheet



Flow Rate Values Cv usg/min.

Estimated values at corresponding opening angle of valve disc

Size DN	25/32	40	50	65	80	100	125	150	200	250	300
20°	3	6	8	8	17	23	44	70	110	203	307
30°	5	13	19	19	38	56	95	151	267	406	606
40°	9	28	41	41	83	110	191	273	539	824	1'154
50°	16	50	70	70	145	188	296	458	922	1'346	1'995
60°	26	74	107	107	220	296	528	748	1'369	1'868	3'091
70°	37	107	153	153	313	447	748	1'108	2'105	2'807	4'599
80°	46	139	197	197	389	563	945	1415	2796	4234	6914
90°	58	158	224	224	455	679	1'177	1'734	3'538	5'232	8'364

Flow Characteristic

Opening angle of valve disc

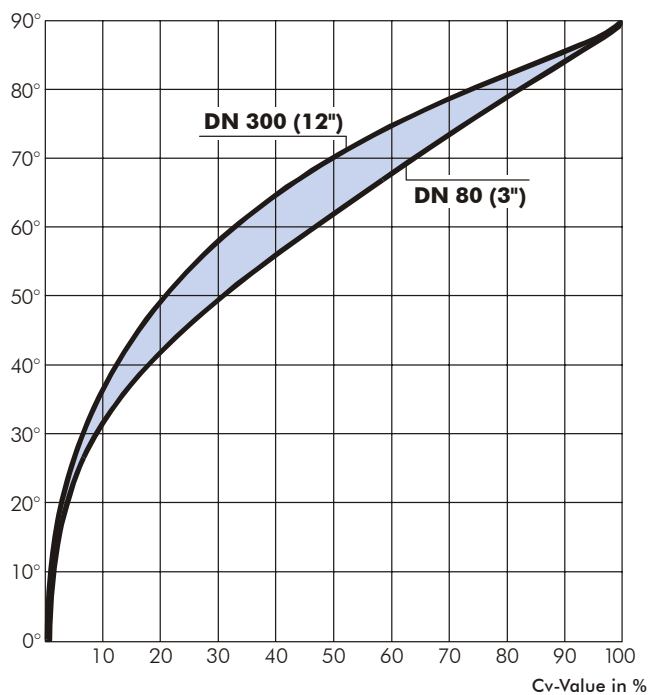

Liquids:

$$K_v = Q \sqrt{\frac{SG}{\Delta p}}$$

Gases:

$$K_v = \frac{Q_N}{514} \sqrt{\frac{SG_N \cdot T}{\Delta p \cdot p_2}}$$

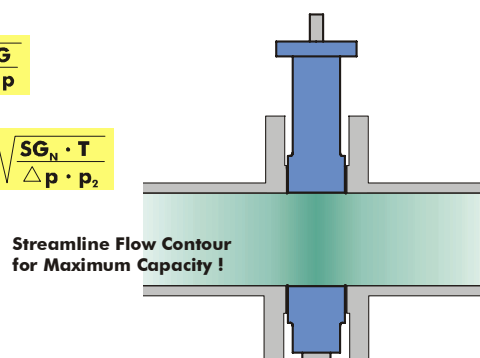

$$^{\circ}K = ^{\circ}C + 273$$

$$K_v = C_v / 1.16$$

Cv (Kv)	Valve Coefficient	usg/min (m ³ /h)
Q	Flow Rate	usg/min (m ³ /h)
Q_N	Flow Rate	usg/min (Nm ³ /h)
SG	Specific Gravity	lbs/usg (kg/dm ³)
SG_N	Specific Gravity	lbs/usg (kg/Nm ³)
P₂	Downstream Pressure	psi (bar)
ΔP	Pressure Drop	psi (bar)
T	Temperature	°K (°C)

Typical Service Applications

- Chemical CPI
- Petro-Chemical
- Bio-Technical
- Pharmaceutical Industry
- Semi-Conductors
- Pulp and Paper
- Food Processing
- Paint and Pigments
- Fertilizers
- Textile Industry
- Mining and Steel
- Desalination



Pressure-/Temperature Diagram

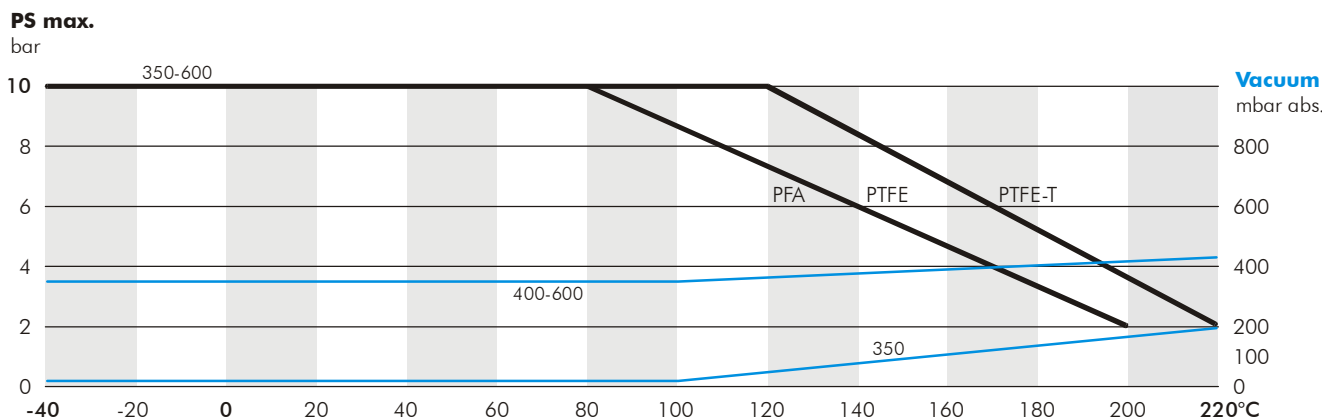

Dimensions in mm



Size DN	A	A1	B	C	D	E	F	G ¹⁾	H	J	K	ISO	T	T1	U	V
350/14"	416	530	92 ²⁾	254	309	40	40	27	340	328	409	F12	-	268	-	168
400/16"	462	596	102	289	339	40	40	27	400	387	459	F12	-	268	-	168
450/18"	512	630	114	308	359	50	50	14	450	436	515	F14	-	275	-	208
500/20"	566	698	127	339	390	50	50	14	500	484	569	F14	-	275	-	208
550/22"	-	758	127	370	421	50	50	14	500	484	619	F14	-	275	-	208
600/24"	668	812	154	399	449	50	50	14	600	578	669	F14	-	298	-	250

Face to face B acc. to DIN EN 558-1 Range 20 ¹⁾ DN450-600: Keyway ²⁾ Range 25, ASME B1.6.10 wide

Torque Values in Nm (in-lbs = Nm x 8.85)

Torque values for PFA-encapsulated disc and specified body liner

Size DN	350	400	450	500	600
A80 PTFE	450	600	740	900	1'200
A81 PTFE-T	495	660	815	990	1'320
A82 PTFE-AS	450	600	740	900	1'200
max. allowable	1'800	1'800	2'000	2'000	2'000

- For liner resp. disc encapsulation never use for both the same material, otherwise considerable increase of torque values must be expected!
- Stated values to be break-away torques without any consideration of safety factors for actuators.

Weights in kg (lbs = kg x 2.2)

Figures stated for execution PTFE/PFA/bare shaft

Size DN	350	400	450	500	600
Lug -style body	85.0	98.0	124.0	132.0	224.0
Wafer -style body	51.0	63.0	76.0	88.0	132.0
Gearbox GG25	8.5	8.5	17.5	17.5	18.0

Weights for pneumatic actuators acc. to separate data sheet

Flow Rate Values Cv usg/min

Estimated values at corresponding opening angle of valve disc

Size DN	350	400	450	500	600
20°	406	592	771	1'032	1'473
30°	766	1'143	1'456	1'879	2'494
40°	1'369	1'717	2'587	3'457	4'849
50°	2'088	2'842	4'466	6'206	8'607
60°	3'341	4'907	7'250	9'454	13'166
70°	5'278	7'598	10'672	13'688	19'082
80°	8'329	10'730	14'210	18'050	24'592
90°	10'162	13'166	17'284	20'880	28'420

Same values to be applied on Butterfly Valves SBE Series elastomer-lined

$K_v = C_v / 1.16$ $°K = °C + 273$

Liquids:

$$K_v = Q \sqrt{\frac{SG}{\Delta P}}$$

Gases:

$$K_v = \frac{Q_N}{514} \sqrt{\frac{SG_N \cdot T}{\Delta p \cdot p_2}}$$

Kv (Cv)	Valve Coefficient	m ³ /h (usg/min)
Q	Flow Rate	m ³ /h (usg/min)
Q_N	Flow Rate	Nm ³ /h (usg/min)
SG	Specific Gravity	kg/dm ³ (lbs/usg)
SG_N	Specific Gravity	kg/Nm ³ (lbs/usg)
P₂	Downstream Pressure	bar (psi)
ΔP	Pressure Drop	bar (psi)
T	Temperature	°C (°K)



Standard Version (Picture showing DN 80 PN16, PTFE liner, PFA-encapsulated disc, bare shaft)

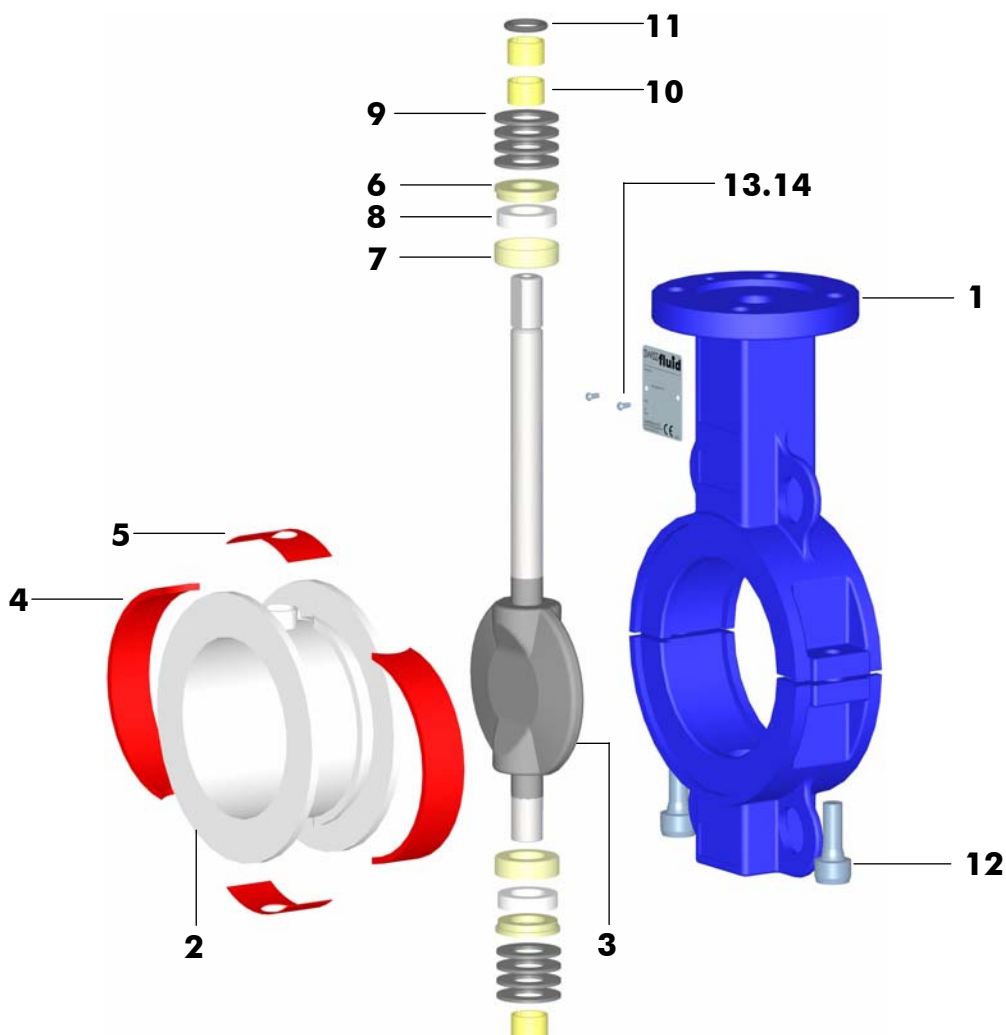

Item	Qty.	Description	Material	No.
1	1	Body two-piece, RAL 5005	WCB	1.0619
2	1	Liner	PTFE	
3	1	Disc encapsulated	Duplex/PFA	1.4462
4	2	Elastomer	VMQ	
5	2	Elastomer Pad	VMQ	
6	2	Pressure Ring	C.Steel	1.0737
7	2	Guide Ring	C.Steel	1.0737
8	2	Elastomer Insert	VMQ	
9	8	Belleville Spring	Spring Steel	1.8159
10	3	Bearing DU	C.Steel/PTFE	
11	1	O-Ring top	FPM	
12	2	Socked Head Cap Screw	A2-70	1.4310
13	1	Name Plate 42 x 14 CE	A2	1.4301
14	2	Hammer Screw 2.49 x 4.76	A2	1.4310



Standard Version (Picture showing DN 80 PN16, PTFE liner, PFA-encapsulated disc, bare shaft)

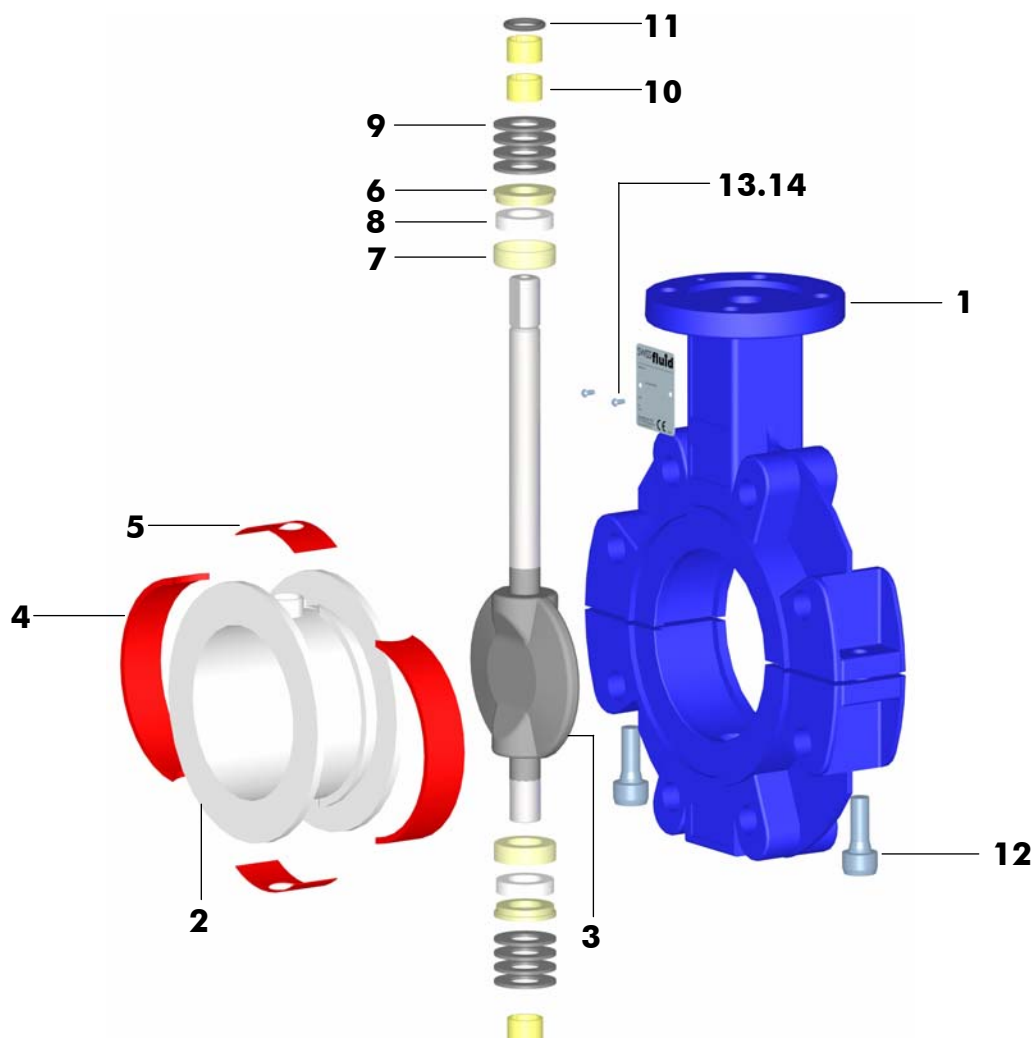

Item	Qty.	Description	Material	No.
1	1	Body Lug two-piece, RAL 5005	WCB	1.0619
2	1	Liner	PTFE	
3	1	Disc encapsulated	Duplex/PFA	1.4462
4	2	Elastomer	VMQ	
5	2	Elastomer Pad	VMQ	
6	2	Pressure Ring	C.Steel	1.0737
7	2	Guide Ring	C.Steel	1.0737
8	2	Elastomer Insert	VMQ	
9	8	Belleville Spring	Spring Steel	1.8159
10	3	Bearing DU	C.Steel/PTFE	
11	1	O-Ring top	FPM	
12	2	Socket Head Cap Screw	A2-70	1.4310
13	1	Name Plate 42 x 14 CE	A2	1.4301
14	2	Hammer Screw 2.49 x 4.76	A2	1.4310

SBP: Specification

51 Butterfly Valves, plastomer-lined

PM 51 M.10 e

April 2003



Project-/Customer Data		Inquiry/Date:	Ref. Swissfluid
Company:	Contact Person:	Phone:	
Address:	Function:	Fax:	
ZIP/Place:	Department:	E-mail:	
Project:	Phone direct:	Mobile:	

Operating Conditions

Media / Chemical Composition:

<input type="checkbox"/> Liquid	<input type="checkbox"/> powdery	<input type="checkbox"/> crystallizing	<input type="checkbox"/> sticky	<input type="checkbox"/> Spez. Grav. ____
<input type="checkbox"/> gaseous	<input type="checkbox"/> Solids ____ %	<input type="checkbox"/> viscous	<input type="checkbox"/> Flow Velocity ____ m/s	
<input type="checkbox"/> abrasive	<input type="checkbox"/> Paricle ____ mm	<input type="checkbox"/> Visc. ____ cp	<input type="checkbox"/> Flow Rate ____ m ³ /h	

Pressure	Temperature	Mode	Installation / Environment	
max. ____ bar	max. ____ °C	<input type="checkbox"/> On/Off	<input type="checkbox"/> horizontal	<input type="checkbox"/> Room dry
min. ____ bar	min. ____ °C	<input type="checkbox"/> Flow Control	<input type="checkbox"/> vertical	<input type="checkbox"/> Room humid
		____ cycles/ ____	<input type="checkbox"/> _____	<input type="checkbox"/> outdoor

Remarks:

Specification of a complete Butterfly Valve SBP Series

